

INSTRUCTION MANUAL

SPECTRACOOL™ **Air Conditioner**

G28 1-Phase Model



McLean®
COOLING TECHNOLOGY

***Protecting Electronics.
Exceeding Expectations.™***

Pentair Technical Products
2100 Hoffman Way
Anoka, MN 55303
☎ +1-763-323-8200
📠 +1-763-576-3200

www.McLeanCoolingTech.com

TABLE OF CONTENTS

| | |
|--|----|
| RECEIVING THE AIR CONDITIONER | 3 |
| HANDLING AND TESTING THE AIR CONDITIONER | 3 |
| HOW TO READ MODEL NUMBERS | 3 |
| DIMENSIONAL DRAWINGS | 4 |
| 4000 BTU 115V | 4 |
| 6000 and 4000 BTU 230V | 4 |
| INSTALLATION INSTRUCTIONS | 5 |
| TECHNICAL INFORMATION | 6 |
| Sequence of Operation | 6 |
| Heating | 6 |
| Cooling | 6 |
| Standard and Optional Component Operation | 6 |
| Thermostat | 6 |
| Head Pressure Control (optional) | 6 |
| 230V to 10V Transformer (optional) | 6 |
| 230V to 24V Transformer and Relay (optional) | 6 |
| Refrigerant Properties Chart (R 407c) | 7 |
| Refrigerant Properties Chart (R 134a) | 7 |
| Functional Data | 8 |
| 4000 BTU Unit Characteristics | 8 |
| 6000 BTU Unit Characteristics | 9 |
| Wire Diagrams and Schematics | 10 |
| 4000 BTU 1-Phase Wire Diagram (actual unit options may vary) | 10 |
| 6000 BTU 1-Phase Wire Diagram (actual unit options may vary) | 11 |
| 4000 BTU 1-Phase Schematic | 12 |
| 6000 BTU 1-Phase Schematic (actual unit options may vary) | 12 |
| SERVICE DATA | 13 |
| Components List | 13 |
| MAINTENANCE | 14 |
| Compressor | 14 |
| Inlet Air Filter | 14 |
| How To Remove, Clean or Install a New Inlet Air Filter | 14 |
| Condenser and Evaporator Air Movers | 15 |
| Refrigerant Loss | 15 |
| TROUBLE SHOOTING | 16 |
| Basic Air Conditioning Trouble Shooting Check List | 16 |
| Symptoms and Possible Causes: | 17 |
| WARRANTY | 18 |
| RETURN AND REPAIR POLICY | 18 |
| LIMITATION OF LIABILITY | 19 |

RECEIVING THE AIR CONDITIONER

Inspect the air conditioner. Check for concealed damage that may have occurred during shipment. Look for dents, scratches, loose assemblies, evidence of oil, etc. Damage evident upon receipt should be noted on the freight bill. Damage should be brought to the attention of the delivering carrier -- NOT to Pentair Technical Products -- within 15 days of delivery. Save the carton and packing material and request an inspection. Then file a claim with the delivering carrier.

Pentair Technical Products cannot accept responsibility for freight damages; however, we will assist you in any way possible.

HANDLING AND TESTING THE AIR CONDITIONER

If the air conditioner has been in a horizontal position, be certain it is placed in an upright, vertical or mounting position for a minimum of five (5) minutes before operating.

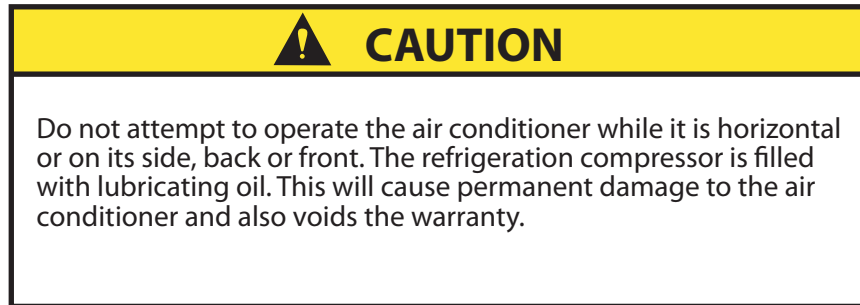

TEST FOR FUNCTIONALITY BEFORE MOUNTING THE AIR CONDITIONER TO THE ENCLOSURE.

Refer to the nameplate for proper electrical current requirements, and then connect the power cord to a properly grounded power supply. Minimum circuit ampacity should be at least 125% of the amperage shown in the design data section for the appropriate model. No other equipment should be connected to this circuit to prevent overloading.

Immediately after applying power, the evaporator blower (enclosure air) should start running. Operate the air conditioner with the compressor running for five (5) to ten (10) minutes. You will need to set the cooling thermostat below the ambient temperature to operate the compressor.

Condenser air temperatures should be warmer than normal room temperatures within a few minutes after the condenser impellers start.

See Sequence of Operation on page 6 for specifics on how the unit operates when powered up.

HOW TO READ MODEL NUMBERS

| | | | | |
|-----|----|---|---|------|
| G28 | 06 | 2 | 6 | G150 |
| 1 | 2 | 3 | 4 | 5 |

1. Identifies the type/family of air conditioner and the approximate height (i.e. G28 = Global family about 28 inch high).
2. This is the air conditioner's listed capacity in BTU/Hr. at rated conditions. (i.e. 06=6,000 BTU/Hr. at 131/131 F)
3. 1 = 115 Volt, 2 = 230 Volt, 4 = 460 Volt.
4. 6 = 50/60 Hz or 60 Hz only.
5. Unique set of numbers for each air conditioner which identifies the accessories on a model.

DIMENSIONAL DRAWINGS

4000 BTU 115V

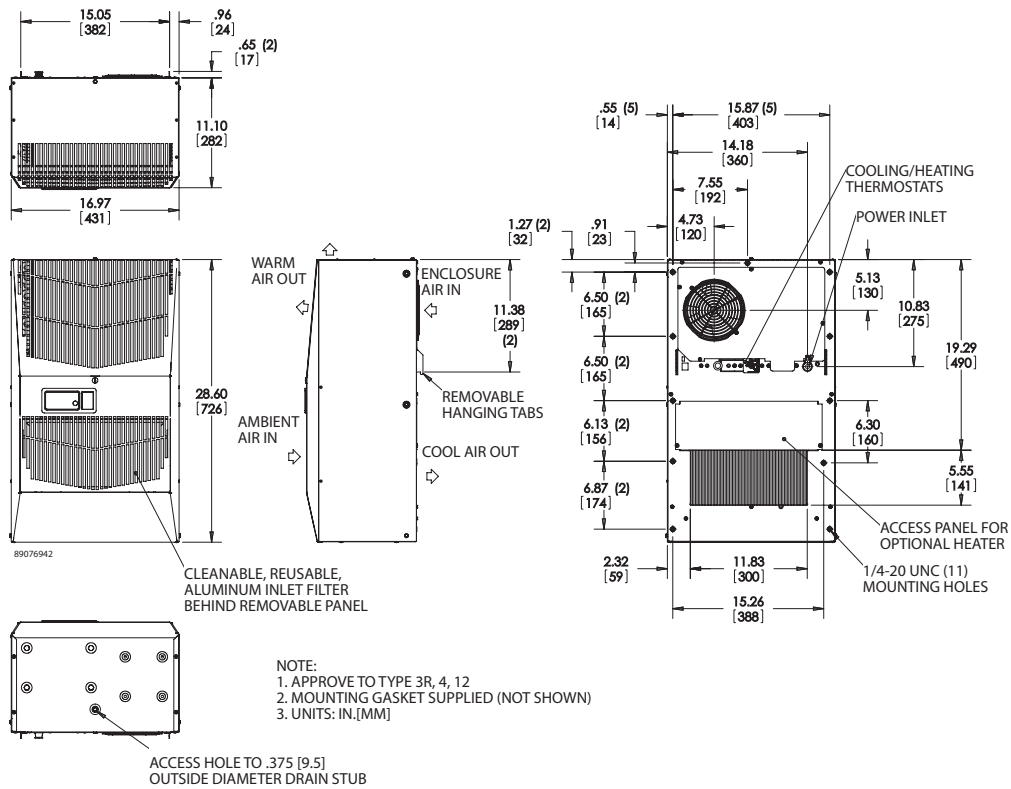

6000 and 4000 BTU 230V

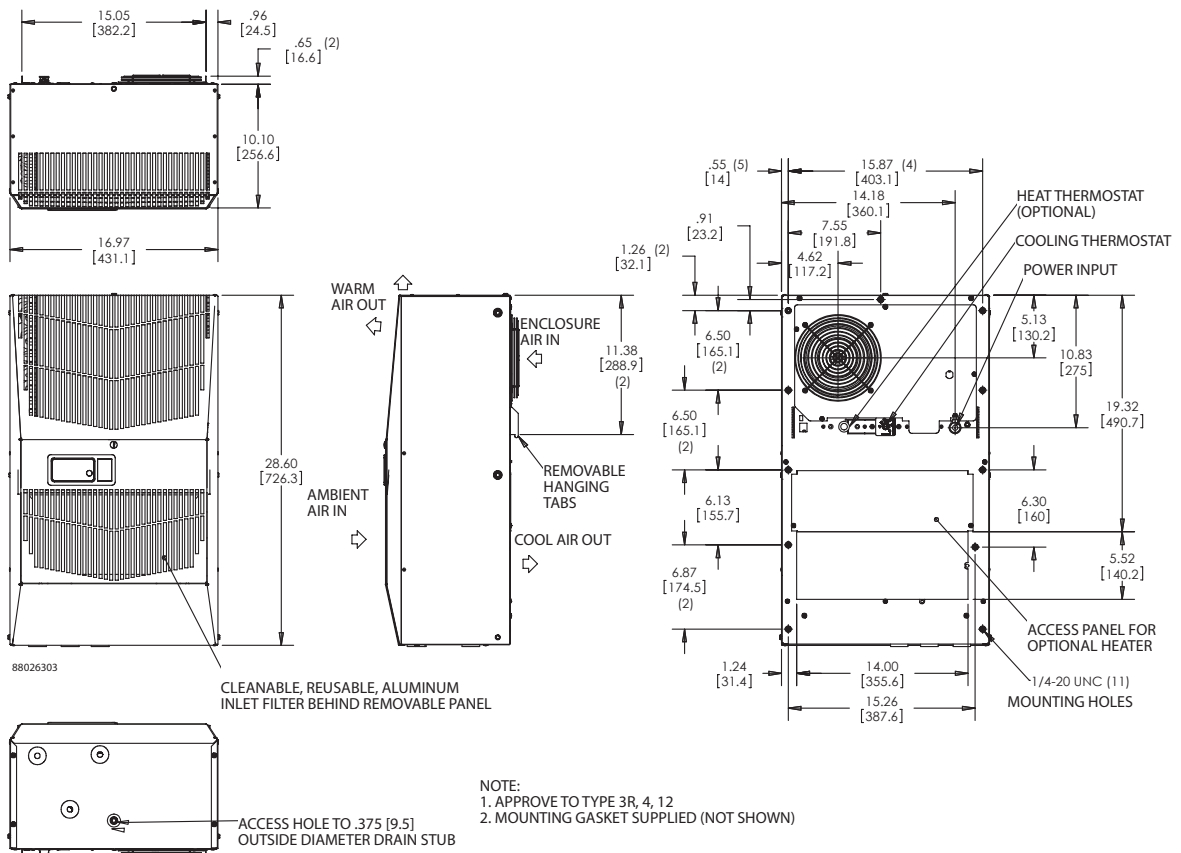

INSTALLATION INSTRUCTIONS

1. Inspect the air conditioner and verify correct functionality before mounting the air conditioner. See HANDLING AND TESTING THE AIR CONDITIONER on page 3.
2. Using the mounting gasket kit provided with the unit, install gaskets to the air conditioner, see Figure 1.
3. Mount air conditioner on enclosure taking care not to damage the mounting gasket. The mounting gasket is the seal between the air conditioner and the enclosure. Avoid dragging the air conditioner on the enclosure with the mounting gasket attached as this could cause rips or tears in the gasket and risk losing the water tight seal.
4. Allow unit to remain upright for a minimum of five (5) minutes before starting. CAUTION! Air conditioner must be in upright position during operation.
5. Refer to the nameplate for electrical requirements. Wire the unit to a properly grounded power supply. Electrical circuit should be fused with slow blow or HACR circuit breaker.
6. Some air conditioners require a remote mounted thermostat. Wire the thermostat outputs to the appropriate terminals on the 24 VAC terminal strip by noting the locations on the correct wiring diagram.
7. Set thermostat for required cabinet temperature. Refer to Sequence of Operation on page 6 for thermostat adjustment and operation.

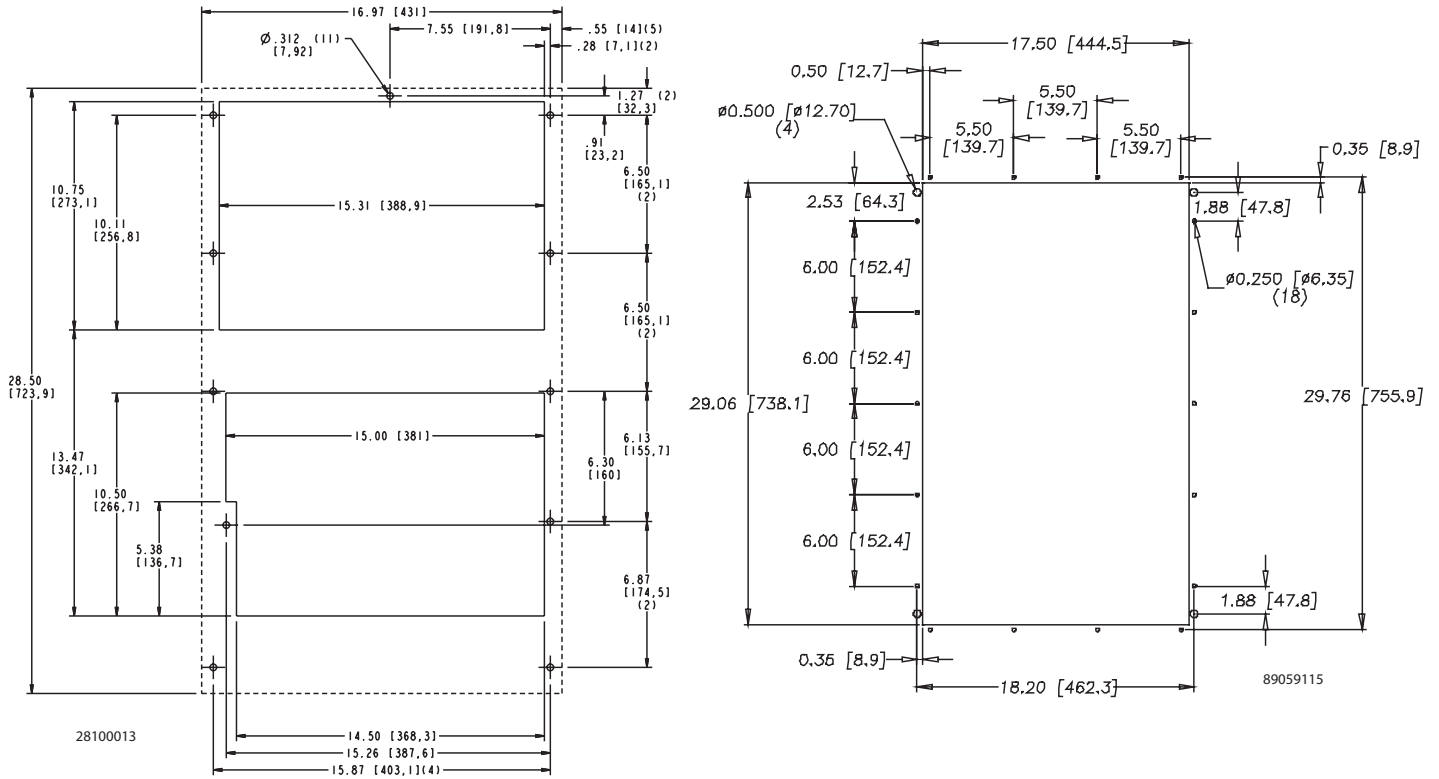

Surface Mount

Partial Recess Mount

Figure 1
Cut-out Drawing

TECHNICAL INFORMATION

Sequence of Operation

The air conditioner comes standard with two internally mounted thermostats. There are two modes of operation; heating and cooling. During heating and cooling modes the evaporator fan will be running.

Heating

When the enclosure temperature is below the heating thermostat setpoint, power is applied to the heaters. When the enclosure temperature is 10 degrees above the setpoint the heater is powered off.

Cooling

When the enclosure temperature is above the cooling thermostat setpoint, power is applied through the thermostat. The compressor is then energized either directly or through a contactor if unit requires one. The condenser impellers will start immediately if the unit is not equipped with an optional head pressure control switch. If the unit is equipped with an optional head pressure control switch, the condenser impellers will start once the refrigerant pressure reaches the setting of the switch. Component specific information is listed below.

Operating the air conditioner below the minimum ambient temperature or above the maximum ambient temperatures indicated on the nameplate voids all warranties. DO NOT set the enclosure thermostat to a temperature lower than 70 F. Doing so can increase the likelihood of frost buildup on the evaporator coil.

The moisture that the enclosure air can contain is limited. If moisture flows from the drain tube continuously this can only mean that ambient air is entering the enclosure. Be aware that frequent opening of the enclosure's door admits humid air that the air conditioner must then dehumidify.

Standard and Optional Component Operation

Thermostat

The G28 air conditioner uses our standard 10-1061-16 thermostat. The thermostat setpoint equals the temperature that the air conditioner turns off. The thermostat has a 10 F differential from setpoint until it calls for cooling or heating. An example of operation is shown below.

For cooling (75-100 F range):

- Thermostat setpoint = 80 F
- Cooling turns on at 90 F
- Cooling turns off at 80 F

For heating (55-65 F range):

- Thermostat setpoint = 55 F
- Heating turns on at 55 F
- Heating turns off at 65 F

NOTE: For testing purposes only, the thermostat stop screw may be removed (on units so equipped) to allow settings below 70 F. After testing, replace the stop screw and verify that the thermostat cannot be set below 70 F. Extended operation below 70 F can cause coil freeze ups resulting in reduced load and/or unit damage.

Head Pressure Control (optional)

Unit is set at the factory, no adjustment necessary.

At a saturated condenser temperature of 82 F (170 psig), the condenser fans will power off. At a saturated condenser temperature of 105 F (240 psig), the condenser fans will power on.

230V to 10V Transformer (optional)

This transformer powers the thermal display only.

230V to 24V Transformer and Relay (optional)

This transformer and relay are used to start/stop the unit thru a customer supplied, remote mounted door switch.

Refrigerant Properties Chart (R 407c)

| °F | °C | Bubble Point (PSIG) | Dew Point (PSIG) | °F | °C | Bubble Point (PSIG) | Dew Point (PSIG) |
|-----|-------|---------------------|------------------|-----|------|---------------------|------------------|
| -40 | -40 | 2.9 | 4.5 | 60 | 15.6 | 117.7 | 96.8 |
| -35 | -37.2 | 5.2 | .7 | 65 | 18.3 | 128.7 | 106.7 |
| -30 | -34.4 | 7.9 | 1.7 | 70 | 21.1 | 140.2 | 117.2 |
| -25 | -31.7 | 10.7 | 4 | 75 | 23.9 | 152.5 | 128.4 |
| -20 | -28.9 | 13.9 | 6.5 | 80 | 26.7 | 165.5 | 140.4 |
| -15 | -26.1 | 17.3 | 9.3 | 85 | 29.4 | 179.2 | 153.1 |
| -10 | -23.3 | 21.1 | 12.4 | 90 | 32.2 | 193.6 | 166.5 |
| -5 | -20.6 | 25.2 | 15.8 | 95 | 35 | 208.8 | 180.8 |
| 0 | -17.8 | 29.6 | 19.5 | 100 | 37.8 | 224.9 | 195.8 |
| 5 | -15 | 34.4 | 23.6 | 105 | 40.6 | 241.8 | 211.8 |
| 10 | -12.2 | 39.6 | 28 | 110 | 43.3 | 259.6 | 228.7 |
| 15 | -9.4 | 45.2 | 32.7 | 115 | 46.1 | 278.2 | 246.5 |
| 20 | -6.7 | 51.3 | 37.9 | 120 | 48.9 | 297.8 | 265.3 |
| 25 | -3.9 | 57.8 | 43.6 | 125 | 51.7 | 318.3 | 285.2 |
| 30 | -1.1 | 64.7 | 49.6 | 130 | 54.4 | 339.9 | 306.1 |
| 35 | 1.7 | 72.2 | 56.2 | 135 | 57.2 | 362.4 | 328.2 |
| 40 | 4.4 | 80.2 | 63.2 | 140 | 60 | 386 | 351.4 |
| 45 | 7.2 | 88.7 | 70.7 | 145 | 62.8 | 410.7 | 375.9 |
| 50 | 10 | 97.8 | 78.8 | 150 | 65.6 | 436.5 | 401.7 |
| 55 | 12.8 | 107.5 | 87.5 | | | | |

Refrigerant Properties Chart (R 134a)

| °F | °C | Pressure (PSIG) | °F | °C | Pressure (PSIG) |
|-----|-------|-----------------|-----|------|-----------------|
| -40 | -40 | -14.7 | 60 | 15.6 | 58 |
| -35 | -37.2 | -12.3 | 65 | 18.3 | 64 |
| -30 | -34.4 | -9.7 | 70 | 21.1 | 71.5 |
| -25 | -31.7 | -6.8 | 75 | 23.9 | 78 |
| -20 | -28.9 | -1 | 80 | 26.7 | 86.7 |
| -15 | -26.1 | 0 | 85 | 29.4 | 95 |
| -10 | -23.3 | 2 | 90 | 32.2 | 105 |
| -5 | -20.6 | 4 | 95 | 35 | 113.3 |
| 0 | -17.8 | 7.5 | 100 | 37.8 | 125 |
| 5 | -15 | 9 | 105 | 40.6 | 135 |
| 10 | -12.2 | 12 | 110 | 43.3 | 146.7 |
| 15 | -9.4 | 15 | 115 | 46.1 | 157.5 |
| 20 | -6.7 | 18.5 | 120 | 48.9 | 170 |
| 25 | -3.9 | 22 | 125 | 51.7 | 185 |
| 30 | -1.1 | 26 | | | |
| 35 | 1.7 | 30 | | | |
| 40 | 4.4 | 35 | | | |
| 45 | 7.2 | 40 | | | |
| 50 | 10 | 45.5 | | | |
| 55 | 12.8 | 51.5 | | | |

Functional Data

| Unit | Evaporator. Air In(°F) | Amps(A) | Condenser Delta(°F) | Evaporator Delta(°F) |
|-------------|------------------------|---------|---------------------|----------------------|
| G280416GXXX | 65-80 | 6.1-8.9 | 16-24 | 11-23 |
| | 80-100 | 6.4-9.4 | 18-31 | 11-25 |
| G280426GXXX | 65-80 | 2.5-3.9 | 25-33 | 19-29 |
| | 80-100 | 2.9-4.6 | 27-38 | 23-33 |
| G280616GXXX | 65-80 | 5.6-7.4 | 24-33 | 24-33 |
| | 80-100 | 6.4-9.1 | 27-38 | 27-37 |
| G280626GXXX | 65-80 | 2.5-3.9 | 25-33 | 19-29 |
| | 80-100 | 2.9-4.6 | 27-38 | 23-33 |

4000 BTU Unit Characteristics

| | Model | |
|---|---|-----------------|
| | G280416GXXX | G280426GXXX |
| Dimensional Data | | |
| Height | 28.55 / 725.2mm | 28.55 / 725.2mm |
| Width | 16.97 / 431.1mm | 16.97 / 431.1mm |
| Depth | 11.10 / 281.9mm | 10.10 / 256.6mm |
| Unit Weight | 82 lbs / 37 kg | 84 lbs / 38 kg |
| Unit Protection Rating | Type 12/4/4X/3R | |
| Cooling Data | | |
| Refrigerant | R134a | R407C |
| Refrigerant Charge | 11.5 oz. | 20 oz. |
| Cooling Capacity at 95 F Enclosure 95 F Ambient (BTU/Hr./W) | 2900 / 3050 | 4300/4600 |
| Cooling Capacity at Max Conditions (BTU/Hr./W) | 3750 / 3950 | 4600/4900 |
| Maximum Ambient Temp | 131 F / 55 C | |
| Minimum Ambient Temp | -40 F / -40 C | |
| Enclosure Airflow | 151 / 183 CFM | 189/221 CFM |
| External Airflow | 284 / 290 CFM | 291/300 CFM |
| Condensate Management | Hose discharge / Optional powered condensate evaporator | |
| Heating Data | | |
| Capacity | 1000 W | 2000 W |
| Electrical Data | | |
| Rated Voltage (50/60 Hz) | 115V | 230V |
| Rated Frequency | 50 / 60 Hz | |
| Voltage Range | +/- 10% of rated | |
| Cooling Amps at Max Conditions | 11.7 / 10.5 | 4.6/5.8 |
| Heating Amps | 16.3 | 9.2 |
| Compressor RLA / LRA | 8.2 / 40 | 2.6/17.7 |
| Evaporator Fan RLA* | .31 | .48 |
| Condenser Fan RLA* | .93 | .53 |

6000 BTU Unit Characteristics

| | Model | |
|---|---|-------------|
| | G280616GXXX | G280626GXXX |
| Dimensional Data | | |
| Height | 28.55 / 725.1 mm | |
| Width | 16.97 / 431.1mm | |
| Depth | 10.10 / 256.6mm | |
| Unit Weight | 84 lbs / 38 kg | |
| Unit Protection Rating | Type 12/4/4X/3R | |
| Cooling Data | | |
| Refrigerant | R407C | |
| Refrigerant Charge | 20 oz. | |
| Cooling Capacity at 95 F Enclosure 95 F Ambient (BTU/Hr./W) | 5600 / 6000 | |
| Cooling Capacity at Max Conditions (BTU/Hr./W) | 6000 / 6400 | |
| Maximum Ambient Temp | 131 F / 55 C | |
| Minimum Ambient Temp | -40 F / -40 C | |
| Enclosure Airflow | 189 / 221 CFM | |
| External Airflow | 291 / 300 CFM | |
| Condensate Management | Hose discharge / Optional powered condensate evaporator | |
| Heating Data | | |
| Capacity | 2000W | |
| Electrical Data | | |
| Rated Voltage (50/60 Hz) | 115V | 230V |
| Rated Frequency | 50 / 60 Hz | |
| Voltage Range | +/- 10% of rated | |
| Cooling Amps at Max Conditions | 9.9 / 11.4 | 4.6/ 5.8 |
| Heating Amps | 18.2 | 9.2 |
| Compressor RLA / LRA | 5.4 / 36.2 | 2.6 / 17.7 |
| Evaporator Fan RLA* | .82 | .48 |
| Condenser Fan RLA* | .93 | .53 |

Wire Diagrams and Schematics

4000 BTU 1-Phase Wire Diagram (actual unit options may vary)

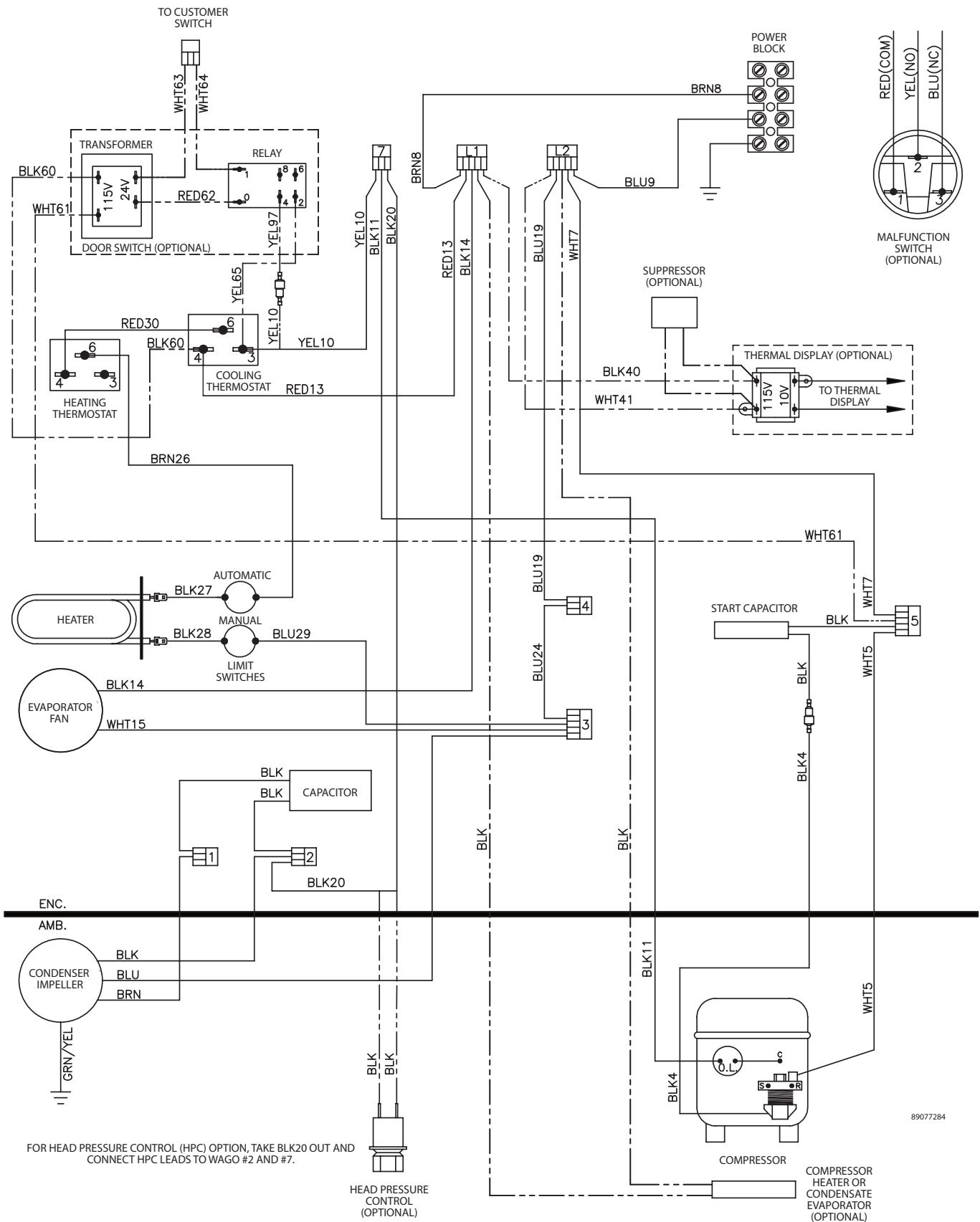

89077284

6000 BTU 1-Phase Wire Diagram (actual unit options may vary)

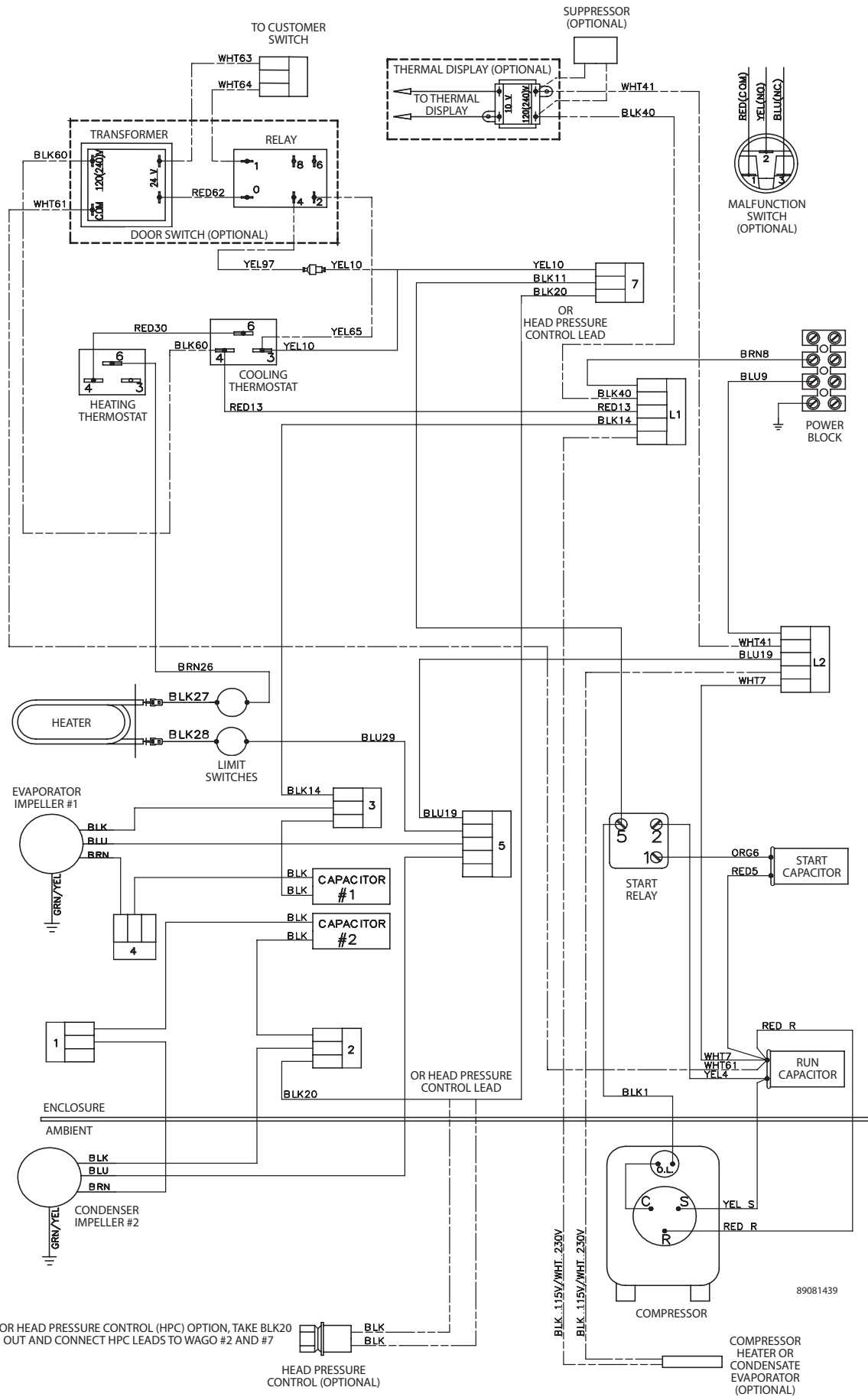

* FOR HEAD PRESSURE CONTROL (HPC) OPTION, TAKE BLK20 OUT AND CONNECT HPC LEADS TO WAGO #2 AND #7

HEAD PRESSURE CONTROL (OPTIONAL)

89081439

COMPRESSOR
HEATER OR
CONDENSATE
EVAPORATOR
(OPTIONAL)

4000 BTU 1-Phase Schematic

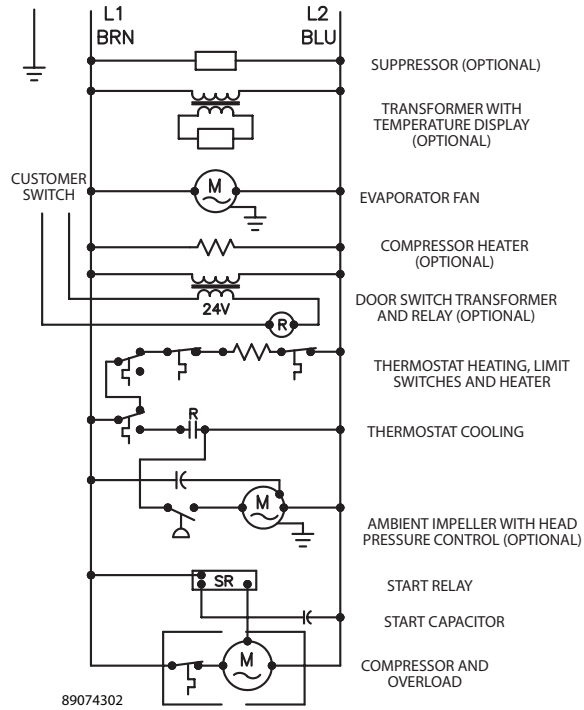

6000 BTU 1-Phase Schematic (actual unit options may vary)

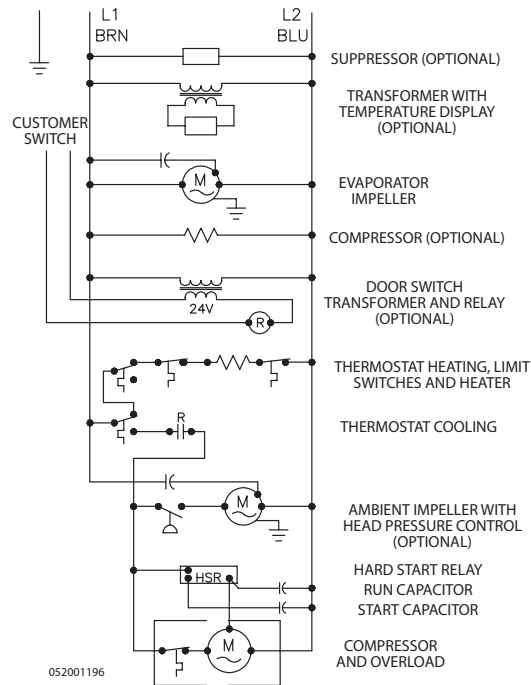

SERVICE DATA

Components List

| Part Description | Part Number | | | |
|--------------------------------|-------------|-------------|-------------|-------------|
| | G280416GXXX | G280426GXXX | G280616GXXX | G280626GXXX |
| Capacitor, Compressor, Start | 85PS110C92 | 10-1032-08 | 10-1032-08 | 10-1032-08 |
| Capacitor, Compressor, Run | N/A | S-6173 | 52-6032-06 | S-6173 |
| Capacitor, Condenser Impeller | 52-6032-13 | 52-6032-14 | 52-6032-13 | 52-6032-14 |
| Capacitor, Evaporator Impeller | N/A | 52-6032-14 | 52-6032-15 | 52-6032-14 |
| Coil, Condenser | 89075089 | 52-6032-14 | 89051206 | 52-6032-14 |
| Coil, Evaporator | 89075090 | 28-6010-00 | 28-6010-00 | 28-6010-00 |
| Compressor | 89069347 | 10-1026-123 | 10-1016-91 | 10-1026-123 |
| Filter, Air, Reusable | 10-1000-107 | 10-1000-107 | 10-1000-107 | 10-1000-107 |
| Filter/Dryer | 52-6028-00 | 52-6028-00 | 52-6028-00 | 52-6028-00 |
| Impeller, Condenser | 10-1091-123 | 10-1091-124 | 10-1091-123 | 10-1091-124 |
| Impeller, Evaporator | 12-1012-01 | 10-1091-122 | 10-1091-121 | 10-1091-122 |
| Relay, Compressor Start | N/A | 10-1042-13 | 10-1042-06 | 10-1042-13 |
| Thermal Expansion Valve | N/A | 89057143 | 89057143 | 89057143 |
| Thermal Overload, Compressor | MRT16AFN-69 | MRA5742-114 | 10-1007-18 | MRA5742-114 |
| Thermostat, SPDT, 55-100F | 10-1061-16 | 10-1061-16 | 10-1061-16 | 10-1061-16 |
| Heater, 2000 Watt | 10-1038-55 | 10-1038-54 | 10-1038-55 | 10-1038-54 |
| Limit Switch (automatic) | 10-1033-01 | 10-1033-01 | 10-1033-01 | 10-1033-01 |
| Limit Switch (manual) | 10-1033-07 | 10-1033-07 | 10-1033-07 | 10-1033-07 |
| Malfunction Switch | 89083014 | 89082840 | 89082840 | 89082840 |
| Head Pressure Control Switch | 89083016 | 89083015 | 89083015 | 89083015 |

MAINTENANCE

Compressor

The compressor requires no maintenance. It is hermetically sealed, properly lubricated at the factory and should provide years of satisfactory operating service.

Under no circumstances should the access fitting covers be loosened, removed or tampered with.

Breaking of seals on compressor access fittings during warranty period will void warranty on hermetic system.

Recharging ports are provided for the ease and convenience of reputable refrigeration repair service personnel for recharging the air conditioner.

Inlet Air Filter

This air conditioner was designed with a dust resistant condenser coil. This allows it to be run filterless in most applications. The air conditioner is shipped with a filter in place for your convenience. For filterless operation, simply remove the filter. Should you decide the filter is necessary in your application, regular maintenance to clean this filter will assure normal operation of the air conditioner. The easily removable inlet air filter is located behind the front cover. If necessary filter maintenance is delayed or ignored, the maximum ambient temperatures under which the unit is designed to operate will be decreased.

If the compressor's operating temperature increases above designed conditions due to a dirty or clogged filter (or plugged condenser coil), the air conditioner's compressor will stop operating due to actuation of the thermal overload cut-out switch located on the compressor housing. As soon as the compressor temperature has dropped to within the switch's cut-in setting, the compressor will restart automatically. However the above condition will continue to take place until the filter or coil has been cleaned. It is recommended that power to the air conditioner be interrupted intentionally when abnormally high compressor operating temperature causes automatic shut-down of the unit. The above described shut-down is symptomatic of a clogged or dirty filter, thus causing a reduction in cooling air flow across the surface of the compressor and condenser coil.

How To Remove, Clean or Install a New Inlet Air Filter

RP aluminum washable air filters are designed to provide excellent filtering efficiency with a high dust holding capacity and a minimum amount of resistance to air flow. Because they are constructed entirely of aluminum they are lightweight and easy to service. To achieve maximum performance from your air handling equipment, air filters should be cleaned on a regular basis.

The inlet air filter is located behind the front access cover. To access the filter, loosen the access-cover screw. Swing top edge of access cover forward. Slide air filter up and out of retaining tabs. The filter may now be cleaned or new filter installed.

Cleaning Instructions:

1. Flush the filter with warm water from the exhaust side to the intake side. **DO NOT USE CAUSTICS.**
2. After flushing, allow filter to drain. Placing it with a corner down will assure complete drainage.

Condenser and Evaporator Air Movers

Impeller motors require no maintenance. All bearings, shafts, etc. are lubricated during manufacturing for the life of the motor.

If one of the condenser impeller motors (ambient impellers) should fail, it is not necessary to remove the air conditioner from the cabinet or enclosure to replace the blower. The condenser blower is mounted on its own bulkhead and is easily accessible by removing the front cover.

|  CAUTION |
|--|
| Operation of the air conditioner in areas containing airborne caustics or chemicals can rapidly deteriorate filters, condenser coils, blowers and motors, etc. Contact Pentair Technical Products for special recommendations. |

Refrigerant Loss

Each air conditioner is thoroughly tested prior to leaving the factory to insure against refrigeration leaks. Shipping damage or microscopic leaks not found with sensitive electronic refrigerant leak detection equipment during manufacture may require repair or recharging of the system. This work should only be performed by qualified professionals, generally available through a local, reputable air conditioning repair or service company.

Should the refrigerant charge be lost, access ports on the suction and discharge sides of the compressor are provided for recharging and/or checking suction and discharge pressures.

Refer to the data on the nameplate which specifies the type of refrigerant and the charge size in ounces.

Before recharging, make sure there are no leaks and that the system has been properly evacuated into a deep vacuum.

TROUBLE SHOOTING

Basic Air Conditioning Trouble Shooting Check List

1. Check manufacturer's nameplate located on the unit for correct power supply.
2. Turn on power to the unit. The evaporator (Enclosure or "COLD" air) impeller should come on. Is there airflow?

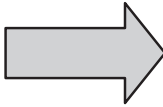
| |
|--|
| YES, proceed to step 3. |
| NO, possible problem: <ul style="list-style-type: none">• Open motor winding• Stuck impeller motor• Obstructed wheel |
|  |
| Repair or Replace defective part |

3. Check thermostat setting and adjust thermostat to the lowest setting. This should turn the condenser impellers and the compressor on. Did condenser impellers and compressor come on when the thermostat was turned on?

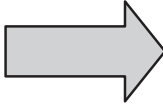
| |
|---|
| YES, proceed to step 4. |
| NO, possible problem: <ul style="list-style-type: none">• Tripped customer door switch• Defective thermostat |
|  |
| Replace part |

4. Are all impellers and the compressor running? If not the unit will not cool properly.
5. Check condenser (Ambient or "HOT" air) impellers for airflow. Is there airflow?

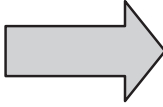
| |
|---|
| YES, proceed to step 6. |
| NO, possible problem: <ul style="list-style-type: none">• Defective thermostat• Open motor winding• Stuck impeller motor• Obstructed wheel |
|  |
| Repair or Replace defective part |

6. Carefully check the compressor for operation - motor should cause slight vibration, and the outer case of the compressor should be warm. Is the compressor showing signs of this?

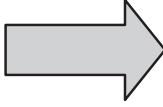
| |
|---|
| YES, wait 5 minutes, then proceed to step 7. |
| NO, possible problem: <ul style="list-style-type: none">• Defective thermostat• Defective overload• Defective relay |
|  |
| Repair or Replace defective part |

7. Make sure the coils are clean. Then check evaporator "air in" and "air out" temperatures. If the temperatures are the same:

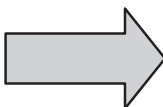
| |
|--|
| <ul style="list-style-type: none">• Possible loss of refrigerant• Possible bad valves in the compressor |
|  |
| Repair or Replace defective part |

8. To check for a bad thermostat, turn power to the unit off. Remove the upper access panel and place both thermostat wires onto one terminal (replace upper access panel for safety). This will activate the switch in the thermostat. Turn the power on and if all impellers and the compressor come on, the thermostat needs to be replaced.

Symptoms and Possible Causes:

| SYMPTOM | POSSIBLE CAUSE |
|---|--|
| Unit won't cool | Clogged fins on coil(s) |
| | Dirty filter |
| | Impellers not running |
| | Compressor not running |
| | Compressor runs, but has bad valves |
| Loss of refrigerant | |
| Compressor tries to start but won't run | Low line voltage at start. Should be +/-10% rated voltage. |
| | Compressor motor stuck |
| | Bad contactor |
| | Bad overload switch |
| | |
| Unit blows breakers | Undersized breaker/fuse or not time delayed |
| | Short in system |
| | |
| Getting water in enclosure | Drain plugged |
| | Drain tube kinked |
| | Enclosure not sealed (allowing humidity in) |
| | Mounting gasket damaged |

For additional technical support, contact Pentair Technical Products at 800-896-2665.

WARRANTY

Pentair Technical Products warrants that the Goods manufactured by Pentair Technical Products will be free from defects in material and workmanship for a period of one (1) year from the date of shipment by Pentair Technical Products, subject to the following conditions and exclusions:

- A. Conditions. All Goods must be installed and operated according to the following specifications:
1. Maximum voltage variation no greater than plus or minus 10% of nameplate nominal rating;
 2. Maximum frequency variation no greater than plus or minus 3 Hz. of nameplate nominal rating;
 3. Must not exceed minimum and maximum stated temperatures on the nameplate;
 4. Must not exceed (BTU/Hr) rating, including any heat sink as indicated on the nameplate;
 5. Refrigerant bearing Goods must not be restarted for a period of one (1) minute after intentional or accidental shut-off;
 6. The filters (if applicable) must be cleaned regularly;
 7. The Goods and any parts thereof must not be modified, unless prior written authorization is received from Pentair Technical Products; and
 8. All Goods must be installed and grounded in accordance with all relevant electrical and safety codes, as well as the National Electric Code and OSHA rules and regulations.
 9. All Goods must be installed in a stationery application, free of vibration.

A violation of any one of these conditions shall render the warranty hereunder void and of no effect.

- B. Exclusions. This warranty shall be void if product is misapplied in any way or:
1. Buyer specified product is inappropriate for system or environment in which it is operating.
 2. Pentair Technical Products product modified in any way without prior written authorization from Pentair Technical Products.
 3. Removal or modification of Pentair Technical Products label affixed to product without written Pentair Technical Products approval.

Pentair Technical Products must be notified of a claim in writing not later than fourteen (14) days from the date when Buyer has become aware of such occurrence, or where the defect is such that it may cause damage, immediately, such notice containing a description of how the defect manifests itself. Failure to provide such prompt notice to Pentair Technical Products shall result in forfeiture of Buyer's rights under this warranty.

In the event of a warranty claim, Buyer is to return defective goods to Pentair Technical Products in accordance with Pentair Technical Products Return Policy. Warranty period for repaired goods remains at 1 year from shipment of original goods. Pentair Technical Products sole obligation to Buyer under this warranty will be, at Pentair Technical Products option:

- A. Repair or replace Pentair Technical Products products or parts found to be defective in material or workmanship.
- B. Issue credit for the purchase price paid by Buyer relating to such defective Goods or part.

THIS WARRANTY CONSTITUTES THE ENTIRE WARRANTY WITH RESPECT TO THE GOODS AND IS IN LIEU OF ALL OTHER WARRANTIES, EXPRESSED OR IMPLIED, INCLUDING ANY IMPLIED WARRANTY OF MERCHANTABILITY AND IMPLIED WARRANTY OF FITNESS FOR A PARTICULAR PURPOSE.

RETURN AND REPAIR POLICY

Pentair Technical Products products that: (i) are made to order, (ii) have been modified by Buyer, (iii) have special finishes, or (iv) are determined by Pentair Technical Products to constitute "custom" products that cannot be returned to stock or resold to other Buyers, will not be accepted for return by Pentair Technical Products.

All returns require a Return Material Authorization number (RMA #), regardless of reason for return, whether it be for warranty or out of warranty repair. Returns without an RMA # will be refused by our Receiving Department. An RMA # is valid for 60 days.

- A. An RMA # will be issued by our Repair Department in Anoka, MN at 866-545-5252. Buyer should have following information available at time of RMA request:

1. Complete Model Number, Serial Number and description of damaged unit being returned.
 2. Original Buyer Purchase Order number and date product was received by Buyer.
 3. Quantity to be returned and a brief description of failure for each unit, if different.
 4. Contact information of Buyer that must include: name of company, billing and shipping address, phone, number, fax number, freight carrier and the name and phone number of a Buyer contact who can elaborate on the claimed defect in detail.
 5. Buyer must provide a Repair Purchase Order number for both warranty and out of warranty repairs. The PO will not exceed 50% of a new unit. Buyer will be notified of repair charges that exceed approved PO amount.
- B. All returns to Pentair Technical Products must be securely packed, using original cartons if possible. All returns must have the RMA number visible on the outside of the carton. Pentair Technical Products is not responsible for material damaged in transit. Any refrigerant-bearing Goods must be shipped upright for return.
- C. Shipping cost for all non-warranty repairs is the responsibility of the sender and must be shipped prepaid. Shipping costs for all warranty related repairs will be covered by Pentair Technical Products provided the goods are returned using a Pentair Technical Products approved carrier. If after diagnoses the product is determined by Pentair Technical Products not be covered under warranty, Buyer will be responsible for all shipping charges and will be billed accordingly.
- D. Non-warranty repairs are subject to a \$75 minimum analysis fee. Analysis fee will be waived if Buyer approves repair work. If approval is not received within 30 days, material will be scrapped and all shipping expenses and corresponding analysis fees will be billed to Buyer.
- E. At Buyer's request, Failure Analysis can be provided by Pentair Technical Products for warrantable goods at no charge. Failure analysis for non-warranty repairs are subject to a \$100 per hour Engineering charge plus any other incurred testing costs.
- F. All returned merchandise must be sent to the following address: Pentair Technical Products, 2100 Hoffman Way, Anoka, MN 55303-1745.
- G. Credit for accepted returns shall be at the original selling price or the current selling price, whichever is lower, less the restocking charge indicated as follows:
1. Within 60 days of invoice date - 20% of applicable selling price.
 2. Within 61-120 days of invoice date - 30% of applicable selling price.
 3. Within 121-180 days of invoice date - 40% of applicable selling price.
 4. Beyond 180 days - subject to individual review by Pentair Technical Products.
- If product being returned for credit requires repair or modification, the cost of any labor or material necessary to bring product into saleable condition will be deducted from credit. Buyer may not take credit against returns without prior written Pentair Technical Products approval.

LIMITATION OF LIABILITY

PENTAIR TECHNICAL PRODUCTS WILL NOT BE LIABLE UNDER ANY CIRCUMSTANCES FOR ANY INCIDENTAL, CONSEQUENTIAL OR SPECIAL DAMAGES, INCLUDING WITHOUT LIMITATION ANY LOST PROFITS OR LABOR COSTS, ARISING FROM THE SALE, USE OR INSTALLATION OF THE GOODS, FROM THE GOODS BEING INCORPORATED INTO OR BECOMING A COMPONENT OF ANOTHER PRODUCT, FROM ANY BREACH OF THIS AGREEMENT OR FROM ANY OTHER CAUSE WHATSOEVER, WHETHER BASED ON WARRANTY (EXPRESSED OR IMPLIED) OR OTHERWISE BASED ON CONTRACT, OR ON TORT OR OTHER THEORY OF LIABILITY, AND REGARDLESS OF ANY ADVICE OR REPRESENTATIONS THAT MAY HAVE BEEN RENDERED BY PENTAIR TECHNICAL PRODUCTS CONCERNING THE SALE, USE OR INSTALLATION OF THE GOODS



McLean[®]
COOLING TECHNOLOGY

***Protecting Electronics.
Exceeding Expectations.™***

Pentair Technical Products
2100 Hoffman Way
Anoka, MN 55303
☎ +1-763-323-8200
📠 +1-763-576-3200

www.McLeanCoolingTech.com

